

fly team vol. 01  
un programma per crescere



**FINITURE E TESSUTI**

Finishes and fabrics. Finishes and fabrics.



L'utilizzo di una nuova gamma di colori, tessuti, di finimenti e di tessuti amplia il target del prodotto e risponde a specifici input del mercato.

The use of a new range of colours, fabrics and finishes widens the product target and meets specific market inputs.

El uso de una nueva gama de colores, tejidos, de finimentos y de tejidos amplia el target del producto y responde a específicos inputs del mercado.



Mobili Industriale SpA  
Via del Prato, 12 - 40027/10028 - Bologna - Italy  
www.mab.it

fly team vol. 01

fly team vol. 01



fly team vol. 01  
un programma per crescere

www.mab.it



mobili per sognare, dal 1902

fly team vol. 01  
un programma per crescere



**CARATTERISTICHE TECNICHE**

Technical characteristics. Características técnicas.



Con Fly team volume 01, Mabi Industriale rappresenta una gamma molto ampia di soluzioni, per un prodotto unico per compatibilità e complementari. Fly team permette una facile personalizzazione attraverso una varietà di colori e dimensioni.

With Fly team volume 01, Mabi Industriale represents a very wide range of solutions, for a product that is unique for modularity and complementarity. Fly team enables easy customization with a range of colours and sizes.

Con Fly team volumen 01, Mabi Industriale representa una gama muy amplia de soluciones, para un producto único por compatibilidad y complementario.

Fly team permite una fácil personalización a través de una variedad de colores y dimensiones.

## 8 TIPOLOGIE DI ANTA. Type of handle. Type de poignée.



## 12 POMOLI e MANIGLIE. Knobs and Handles. Poignées et Têtes.



## CARATTERISTICHE TECNICHE



**Altezza anello** cm. 80,2 - 87,2 - 94,2 - 101,2  
**Altezza maniglia** cm. 80,2 - 87,2 - 94,2 - 101,2  
**Altezza pomolo** cm. 80,2 - 87,2 - 94,2 - 101,2  
**Spessore anello** mm. 12  
**Spessore maniglia** mm. 12  
**Spessore pomolo** mm. 12  
**Altezza pomolo a T** cm. 80,2 - 87,2 - 94,2 - 101,2  
**Altezza maniglia a T** cm. 80,2 - 87,2 - 94,2 - 101,2  
**Altezza pomolo a L** cm. 80,2 - 87,2 - 94,2 - 101,2  
**Altezza maniglia a L** cm. 80,2 - 87,2 - 94,2 - 101,2  
**Altezza pomolo a D** cm. 80,2 - 87,2 - 94,2 - 101,2  
**Altezza maniglia a D** cm. 80,2 - 87,2 - 94,2 - 101,2

**TECHNICAL CHARACTERISTICS**  
**Height of ring** cm. 80,2 - 87,2 - 94,2 - 101,2  
**Height of handle** cm. 80,2 - 87,2 - 94,2 - 101,2  
**Height of knob** cm. 80,2 - 87,2 - 94,2 - 101,2  
**Ring thickness** mm. 12  
**Handle thickness** mm. 12  
**Knob thickness** mm. 12  
**Height of T knob** cm. 80,2 - 87,2 - 94,2 - 101,2  
**Height of T handle** cm. 80,2 - 87,2 - 94,2 - 101,2  
**Height of L knob** cm. 80,2 - 87,2 - 94,2 - 101,2  
**Height of L handle** cm. 80,2 - 87,2 - 94,2 - 101,2  
**Height of D knob** cm. 80,2 - 87,2 - 94,2 - 101,2  
**Height of D handle** cm. 80,2 - 87,2 - 94,2 - 101,2

**CARACTERÍSTICAS TÉCNICAS**  
**Altezza anello** cm. 80,2 - 87,2 - 94,2 - 101,2  
**Altezza maniglia** cm. 80,2 - 87,2 - 94,2 - 101,2  
**Altezza pomolo** cm. 80,2 - 87,2 - 94,2 - 101,2  
**Spessore anello** mm. 12  
**Spessore maniglia** mm. 12  
**Spessore pomolo** mm. 12  
**Altezza pomolo a T** cm. 80,2 - 87,2 - 94,2 - 101,2  
**Altezza maniglia a T** cm. 80,2 - 87,2 - 94,2 - 101,2  
**Altezza pomolo a L** cm. 80,2 - 87,2 - 94,2 - 101,2  
**Altezza maniglia a L** cm. 80,2 - 87,2 - 94,2 - 101,2  
**Altezza pomolo a D** cm. 80,2 - 87,2 - 94,2 - 101,2  
**Altezza maniglia a D** cm. 80,2 - 87,2 - 94,2 - 101,2

## COLLEZIONE TESSUTI



Fabrics collection. Colección tejidos.

**7 TESSUTI COLOUR. Colour fabric. Tapis Color. COLECCIÓN A**



**6 TESSUTI CINGHIA. Check fabric. Tapis Check. COLECCIÓN B**



**7 TESSUTI ECOPELLE. Laminated fabric. Tapis Ecopelle. COLECCIÓN A**



**5 TESSUTI GIROTONDO. Circular fabric. Tapis Circular. COLECCIÓN A**



**3 TESSUTI FLOR. Flower fabric. Tapis Flor. COLECCIÓN A**



**3 TESSUTI RIGATO. Striped fabric. Tapis Rigato. COLECCIÓN A**



## FINITURE



Finishes. Acabados.

**4 ESSENZE LAMINATO. Laminated woods. Ebanos laminados.**



**10 COLORI LAMINATI. Laminated colours. Colores laminados.**



**22 COLORI LACCATI. Lacquered colours. Colores lacados.**



**5 FINITURE SIMILVETRO. Simulated glass finishes. Acabados imitación vidrio.**





mobili per sognare dal 1962

- |     |  |   |
|-----|--|---|
| 04  | <b>SISTEMA MONTANTE</b><br>THE UPRIGHT SYSTEM EL SISTEMA DE MONTAJE  |    |
| 10  | <b>RIPIANO LUNGO</b><br>LONG SHELF ESTANTE LARGO                     |    |
| 20  | <b>PEDANE E SPAZIO "C"</b><br>C SPACE ESPACIO C                      |    |
| 28  | <b>GADGET</b><br>GADGETS GADGET                                      |   |
| 34  | <b>LIBRERIA SPALLA</b><br>SHOULDER BOOKCASE LIBRERIA ESTRIBO         |  |
| 46  | <b>BOISERIE</b><br>BOISERIE BOISERIE                                 |  |
| 64  | <b>CASTELLI</b><br>BUNK BEDS LITERAS                                 |  |
| 76  | <b>PONTI E SOPPALCHI</b><br>BRIDGES AND GALLERIES PUENTES Y ALTILLOS |  |
| 114 | <b>SALVASPAZIO</b><br>THE ROOM SAVERS LOS SALVASPAZIO                |  |
| 130 | <b>ARMADI</b><br>CUPBOARDS ARMARIOS                                  |  |
| 144 | <b>L'ARCHIVIO</b><br>THE ARCHIVE EL ARCHIVO                          |  |
| 146 | <b>COMPLEMENTI</b><br>COMPLEMENTS COMPLEMENTOS                       |  |

**flyteam** un programma per crescere



### MOBILI PER SOGNARE DAL 1962

1962: MAB, UNA DELLE MAGGIORI AZIENDE DI MOBILI ITALIANE, NASCE A MEDUNA DI LIVENZA, IN PROVINCIA DI TREVISO, SI DISTINGUE PER LA SUA COSTANTE EVOLUZIONE TECNOLOGICA E SI DIMOSTRA PARTICOLARMENTE SENSIBILE ALLE NUOVE TENDENZE INTERNAZIONALI DI DESIGN DA CUI MAB INDUSTRIE HA TRATTO ISPIRAZIONE PER PRODURRE LE SUE COLLEZIONI.

DREAM FURNITURE SINCE 1962  
1962: MAB, one of the leading Italian furniture companies, was established in Meduna di Livenza, province of Treviso. The firm stands out for its constant technological development and shows particular interest in the new international design trends that MAB Industrie has drawn from for producing its collections.

MUEBLES PARA SOÑAR DESDE 1962  
1962: mab, una de las más importantes empresas italianas de muebles, nació en Meduna de Livenza, en provincia de Treviso. Se distingue por su constante evolución tecnológica y se demuestra especialmente sensible a las nuevas tendencias internacionales de diseño de las que mab industries ha traído inspiración para producir sus colecciones.



### PANNELLO ECOLOGICO

IL PANNELLO ECOLOGICO È UN PANNELLO IN LEGNO RICICLATO UTILIZZATO NELLA PRODUZIONE DI MOBILI. È L'UNICO AL MONDO REALIZZATO ESCLUSIVAMENTE CON REIMPIEGO DI LEGNO, MEDIANTE UN PROCESSO PRODUTTIVO CHE RISPETTA L'AMBIENTE PERCHÉ NON COMPORTA L'ABBATTIMENTO DI ALBERI. ATTENZIONE PER L'AMBIENTE. VERNICI ALL'ACQUA PER I NUOVI COLORI LACCATI, UTILIZZO DI PANNELLI ECOLOGICI. MAB INDUSTRIE UTILIZZA IL PANNELLO IN LEGNO RICICLATO RISPETTANDO L'AMBIENTE.

#### ECOLOGICAL PANEL

The ecological panel is a panel in recycled wood, used in the production of the furniture. It is the only one of its kind made exclusively with the reuse of wood, by means of a production process that respects the environment, because it does not involve the cutting of trees. Attention to the environment: water paints for the new lacquered colours, the use of ecological panels. MAB INDUSTRIE uses the panel in recycled wood, respecting the environment.

#### PANEL ECOLÓGICO

El panel ecológico es un panel de madera reciclada utilizado en la fabricación de muebles. Es el único en el mundo realizado exclusivamente con reutilización de maderas, mediante un procedimiento de fabricación que respeta el medio ambiente porque no requiere la tala de árboles. Como cuidado al medio ambiente: barnices al agua para los nuevos colores lacados, utilización de paneles ecológicos. MAB INDUSTRIE utiliza el panel de madera reciclada respetando el mundo ambiente.

### IL GRILLO

MAB INDUSTRIE PRESENTA LA NUOVA VERSIONE DEL MASCOTTE AZIENDALE, IL SIMPATICISSIMO GRILLO VERDE CHE CI GUIDA DA UNA COLLEZIONE ALL'ALTRA CON LA SUA INESAURIBILE CURIOSITÀ.

#### THE CRICKET

MAB INDUSTRIE presents the new version of the company mascot, the charming green cricket that guides us from one collection to another, with its boundless curiosity.

#### EL GRILLO

MAB INDUSTRIE presenta la nueva versión de su mascota de empresa, el simpaticísimo grillo verde que nos guía de una colección a otra con su insaciable curiosidad.

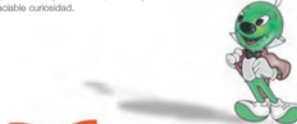

### SITO INTERNET

VISITA IL NUOVISSIMO SITO WWW.MAB.IT UNA GRAFICA MODERNA E AGGIORNATA TI PRESENTA IN TEMPO REALE LE IMMAGINI E LE MIGLIORI INFORMAZIONI SULLE COLLEZIONI MAB INDUSTRIE.

#### INTERNET SITE

Visit the brand-new website WWW.MAB.IT modern and up-to-date graphics will present the images and best information on the MAB INDUSTRIE collections in real-time.

#### SITO INTERNET

Visita nuestro nuevísimo sitio www.mab.it una gráfica moderna y actualizada te presenta en tiempo real las imágenes y las mejores informaciones acerca de las colecciones MAB INDUSTRIE.

### PROGRAMMA GRAFICO

MAB INDUSTRIE TI OFFRE LA POSSIBILITÀ DI COMPORRE LA CAMERETTA A TUO PIACERE RENDENDOLA L'UNICA COME TE. RICHIEDI IL PROGRAMMA GRAFICO CON CUI DISEGNARE LA TUA CAMERETTA.

#### GRAPHIC PROGRAMME

MAB INDUSTRIE offers the possibility of composing the children's bedroom the way you want, making it unique like you. Request the graphic programme for designing your children's bedroom.

#### PROGRAMA GRÁFICO

MAB INDUSTRIE te ofrece la posibilidad de componer la habitación a tu gusto, haciéndola única como tú. Solicita el programa gráfico para diseñar tu habitación.



### ISTRUZIONI PER IL MONTAGGIO

MAB INDUSTRIE FORNISCE AI PROPRICI CLIENTI UN RICCO MATERIALE INFORMATIVO CHE ILLUSTRATA NEI DETTAGLI LE CARATTERISTICHE TECNICHE. LE ISTRUZIONI DI MONTAGGIO, I CONSIGLI DI MANUTENZIONE RELATIVI A TUTTI I PRODOTTI ACQUISTATI.

#### ASSEMBLY INSTRUCTIONS

MAB INDUSTRIE supplies its customers with lots of literature illustrating in detail the technical characteristics, assembly instructions, and advice on care for all the products purchased.

#### INSTRUCCIONES PARA EL MONTAJE

MAB INDUSTRIE proporciona a sus clientes un rico material informativo que explica detalladamente las características técnicas, las instrucciones de montaje, los consejos de mantenimiento relativos a todos los productos adquiridos.



sedia Flexa imbottita girevole padded swivel chair silla tapizada giratoria.



### CAMPAGNA PUBBLICITARIA

MAB INDUSTRIE RAGGIUNGE IL SUO PUBBLICO ATTRAVERSO LE PIU' IMPORTANTI RIVISTE ITALIANE DELL'ARREDAMENTO. CON UN ACCURATO PLANNING PUBBLICITARIO CHE INFORMA E AGGIORNA MENSILMENTE LA CLIENTELA SU TUTTE LE PROPOSTE D'ARREDO.

#### ADVERTISING CAMPAIGN

MAB INDUSTRIE reaches its public through the most important Italian furnishing magazines, with careful advertising planning that, on a monthly basis, informs and updates customers about all the furnishing proposals.

#### CAMPANA PUBLICITARIA

MAB INDUSTRIE llega a su público a través de las más importantes revistas italianas de decoración, con un cuidadoso planning publicitario que informa y actualiza mensualmente a sus clientes acerca de todas las propuestas de decoración.

## SISTEMA MONTANTE

THE UPRIGHT SYSTEM. EL SISTEMA DE MONTAJE.

Ad ogni spazio la sua libertà compositiva. Il sistema montante realizza dinamiche mensole porta libri, con il sistema di fissaggio "Gabbiano".

To every space its compositional liberty. The upright system creates dynamic bookshelves, with the "Gabbiano" fixing system.

Para cada espacio, su libertad de composición. El sistema montante realiza repisas dinámicas porta-libros, con el sistema de fijación "Gabbiano".



701  
composizioni





composizione **701**

Armadio H. 227,2 cm.

**finiture** finishes, acabados.

**finiture struttura**  
structure finishes  
acabados estructura

**Cilegio**  
cherrywood, cerezo

**finiture frontali**  
front finishes  
acabados frontales

**Vaniglia**  
vanilla, vainilla



UNA **CABINA**  
PER **CONTENERE**

A CONTAINING CABIN CABINA CONTENEDOR



703

composizione

L'attrezzatura è versatile e dinamica. I piani scrittoio si possono sagomare a piacere. Ma attenzione non sono possibili sagomature con profondità superiore ai 95 cm.

Dynamic and versatile fittings. Choose for the desk top the shape you like. Please note, however, that you cannot have shapes deeper than 95 cm.

El equipo es versátil y dinámico. Los tableros del escritorio se pueden perfilar según guste. Mas atención, no es posible perfilar con profundidad superior a los 95 cm.



composizione 703

Armadio H. 259,2 cm.

finiture finishes, acabados.

finiture struttura  
structure finishes  
acabados estructura

■ Ciliegio  
cherrywood, cerezo

finiture frontali  
front finishes  
acabados frontales

■ Blu  
blue, azul marino

■ Finta  
fanta, fanta.

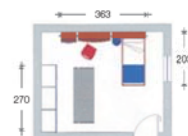

## RIPIANO LUNGO

LONG SHELF ESTANTE LARGO

Un quadrato colorato scorre tra i ripiani: scegli tu cosa vuoi nascondere, e cosa vuoi tenere a portata di mano. In alto, un ripiano resta sempre a vista, luogo ideale per scatole e raccoglitori.

A coloured square slides between the shelves: you choose what to hide and what to keep right at hand. Higher up, one shelf will always be open, ideal place for boxes and binders.

Un cuadrado coloreado se desliza entre las repisas: tú eliges lo que quieres ocultar y lo que quieres tener al alcance de tu mano. Arriba, hay un anaquel que queda siempre visible, y es ideal para guardar cajas y archivadores.



704

composizione





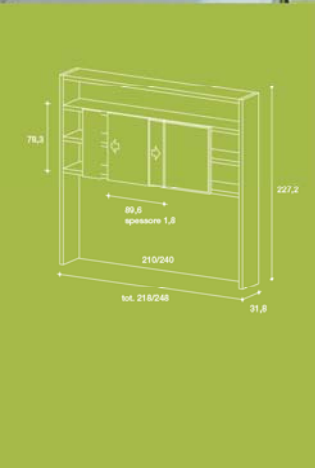

composizione 704 Armadio H. 227,2 cm

finiture finishes, acabados.

finitura struttura  
structure finishes  
acabados estructura

□ Bianco  
white, blanco

finitura frontali  
front finishes  
acabados frontales

■ Verde Mela  
apple green, verde manzana,  
■ Azzurro shock  
shocking blue, azul shock





705

composiziona





## molteplici soluzioni compositive e di utilizzo

Multiple solutions for both assembly and use / Múltiples soluciones de composición y de uso

"Tecno". La consolle che sorregge la tastiera diviene una comoda e spaziosa scrivania.

"Tecno". The keyboard holding console becomes a handy and roomy "Tecno".

La consolle donde se apoya el teclado se convierte en un escritorio cómodo y amplio.



composizione 705

Armadio H. 227,2 cm.

finiture finishes, acabados.

finiture struttura  
structure finishes  
acabados estructura

Blanco  
white, blanco

finiture frontali  
front finishes  
acabados frontales

Verde Mela  
apple green, verde manzana,  
Sky  
blue (sky), celeste (sky)  
Fanta  
fanta, fanta.

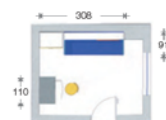

## SFIDA LO SPAZIO...

CHALLENGES SPACE... DESAFÍA EL ESPACIO...



## GIORNO E NOTTE

DAY AND NIGHT · NOCHE Y DÍA



composizione 706

Armadio H. 227,2 cm.

finiture finishes, acabados.

finiture struttura  
structure finishes  
acabados estructura

Blanco  
white, blanco

finiture frontali  
front finishes  
acabados frontales

Sky  
blue (sky), celeste (sky)  
Blu  
blue, azul marino  
Giallo  
yellow, amarillo



composizione 707

Armadio H. 227,2 cm.

finiture finishes, acabados.

finiture struttura  
structure finishes  
acabados estructura

Blanco  
white, blanco

finiture frontali  
front finishes  
acabados frontales

Fanta  
fanta, fanta.  
Verde Mela  
apple green, verde manzana.

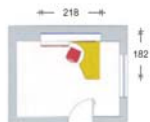



709

composizione

## PEDANE E SPAZIO "C"

C SPACE ESPACIO C

Spazio "C" vuol dire un'alta concentrazione di attrezzature per un'inedita e compatta zona studio o piani girevoli di servizio. Lo scrittoio ruota attorno alla seduta con cuscino in appoggio allo spazio "C".

"C" space means lots of equipment for a novel and compact study area or handy swivel tops. The writing desk revolves round the cushioned seat attached to the "C" space.

Espacio "C" significa una elevada concentración de elementos para una novedosa y compacta zona estudio o tableros giratorios de servicio. El escritorio gira alrededor del asiento con cojín apoyado en el espacio "C".



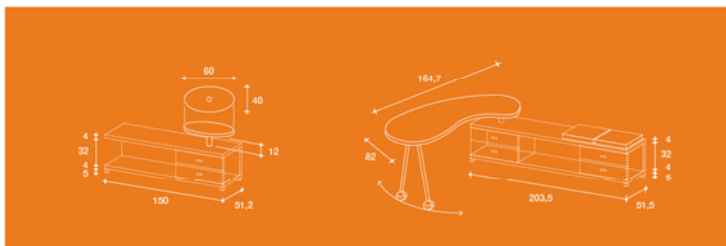

composizione **709** Armadio H. 227,2 cm.

**finiture** finishes, acabados.

**finiture struttura**  
structure finishes  
acabados estructura

**Faggio**  
beech, haya

**finiture frontali**  
front finishes  
acabados frontales

**Faggio**  
beech, haya  
**Fanta**  
fanta, fanta.

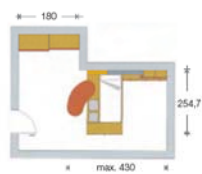

## piani girevoli di servizio

handy swivel tops tableros giratorios de servicio

Spazio "C" è la variabile che trasforma la pediera del letto in complesso multimediale.

Space "C" is the variable that transforms the bed-end into a multimedia complex.

Espacio "C" es la variable que convierte la tarima de la cama en un conjunto multimedial.



# 710

composizione



composizione 710

Armadio H. 227,2 cm.

finiture finishes, acabados.

finiture struttura  
estructura finishes  
acabados estructura

Faggio  
beech, haya

Bianco  
white, blanco

finiture frontali  
front finishes  
acabados frontales

Faggio  
beech, haya

Verde Mela  
apple green, verde manzana.

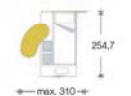
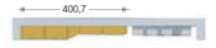



711  
composizione

uno spazio da riempire

A space to fill. Un espacio a llenar.



composizione **711** Armadio H. 227,2 cm.

finiture finishes, acabados.

finiture **struttura**  Bianco  
 estructura finishes white, blanco.  
 acabados estructura

finiture **frontali**  Fanta  
 front finishes fantasia, fanta.  
 acabados frontales  Blu  Blu  
 blue, azul marino





## GADGET

GADGETS GADGET

### mensola con schienale

the shelf with a back / la repisa con el respaldo

E' mensola doppia a boiserie, da usare come elemento di collegamento, per chiudere a muro una composizione con la comoda portata di ripiani in vetro o colorati.

It's a double boiserie shelf, a linking element, to close any composition on the wall, and make the most of the glass or coloured shelves capacity.

Es una repisa doble a boiserie, que se utiliza como elemento de conexión, para cerrar con un panel a pared una composición con la comodidad y la capacidad de anaqueles de cristal o coloreados.



## i cubotti

the cubes / los cubos

In incastro uno sull'altro, possono ruotare formando strutture dinamiche ad uso comodino o libreria. Di grande utilità nella creazione di scrittoi singoli e doppi.

Arranged one onto the other, they can rotate and form dynamic structures, to make a bedside table or bookcase. Very useful to create single and double writing desks.

Encastrados uno en el otro, pueden girar formando estructuras dinámicas que sirven de mesita de noche o de librería. Muy útil en la creación de escritorios individuales o dobles.



finiture cubotti  
cubes finish  
acabados cubos

Blanco	white, blanco	Cedro	cedar green, cedro
Vaniglia	vanilla, vanilla	Mango	mango, mango
Verde mela	apple green, verde manzana	Moka	Mocha, Moka
Verde acqua	water green, verde agua	Tortora	turtle-dove grey, gris centolento
Azzurro Shock	shocking blue, azul shock	Visone	mink, visón
Blu	blue, azul marino	Tabacco	tobacco, tabaco
Sky	blue (sky), celeste (sky)	Milka	milka, milka
Fanta	orange (fanta), naranja (fanta)	Verde Pistacchio	peistachio green, verde pistachio
Giallo	yellow, amarillo	Verde Prato	meadow green, verde prado
Rosso 100%	100% Red, Rojo 100 %	Bordeaux	bordeaux, burdeos
Rosso mattone	brick red, rojo ladrillo	Alluminio	aluminum, aluminio

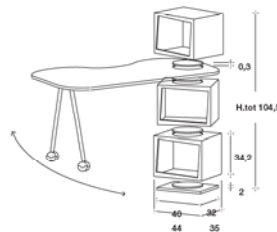



## i contenitori alveare

the honeycombed containers los contenedores "colmena"

La libreria diventa allegra, con le caselle con cui ordinare gli oggetti. Si possono disporre e se ne può disporre a piacere in diversi moduli e creative composizioni.

The bookcase turns bright and cheerful, with its pigeon holes to tidy things away. They can be arranged at will, as many as you like, with different modules in many creative compositions.

La librería se vuelve alegre, con las estanterías en las que se mantienen ordenados los objetos. Se pueden colocar y son disponibles según el gusto en módulos diferentes y composiciones creativas.

L. 56 P. 29,6 H. 61,8 cm. L. 86 P. 29,6 H. 61,8 cm.



finiture alveari  
honeycombed finish  
acabados "colmena"

Bianco white, blanco	Cedro cedar green, cedro
Vaniglia vanilla, vanille	Mango mango, mangle
Verde melia apple green, verde manzana	Moka Mocha, Moka
Verde acqua aqua green, verde agua	Tartora turtle-dove grey, gris cisneante
Azzurro Shock shocking blue, azul shock	Visone mink, visón
Blu blue, azul marino	Tabacco tobacco, tabaco
Sky blue (sky), celeste (sky)	Mikla mika, mika
Fanta orange (fanta), naranja (fanta)	Verde Pistacchio peach green, verde pistacho
Giallo yellow, amarillo	Verde Prato maslow green, verde prado
Rosso 100% 100% Red, Rojo 100 %	Bordeaux bordeaux, burdeos
Rosso mattone brick-red, rojo ladrillo	Alluminio aluminium, aluminio



## le mensole

the shelves las repisas

Da agganciare con il sistema Gabbiano per creare librerie nello spazio, con divisori reggilibri in metacrilato e la sagomatura stondata del bordo salvacaduta o più semplicemente a spessore 4 cm.

To hook using the Gabbiano system and create bookcases in space, with methacrylate bookends with a rounded protection border or, rather simply, showing off the full 4 cm thickness.

A enganchar con el sistema Gabbiano para crear librerías en el espacio, con tabiques sujetalibros de metacrilato y la moldura redondeada del borde para impedir la caída, o simplemente sin borde con un espesor de 4 cm.

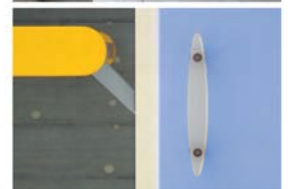

## la pleximensola

the plexishelf la plexirepsia

Un montaggio ultrafacile. In quattro fantastici colori sfida le consuetudini con spensierata ironia, e la gravità con alette reggi libro.

Very easy to assemble. In four fantastic colours, it challenges habit with carefree irony, and gravity with book holding wings.

Muy fácil de montar. Con sus cuatro fabulosos colores desafía las costumbres con despreocupada ironía, mientras desafía las leyes de gravedad con sus pequeñas alas sujeta-libros.

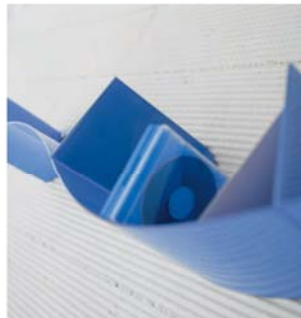

<p>finitura <b>pleximensola</b> plexishelf finish acabados plexirepsia</p>	<ul style="list-style-type: none"> <li><span style="display: inline-block; width: 15px; height: 15px; background-color: orange; border: 1px solid black; margin-right: 5px;"></span> <b>Arancio</b> orange, naranja</li> <li><span style="display: inline-block; width: 15px; height: 15px; background-color: blue; border: 1px solid black; margin-right: 5px;"></span> <b>Blu</b> blau, azul marino</li> <li><span style="display: inline-block; width: 15px; height: 15px; background-color: #90EE90; border: 1px solid black; margin-right: 5px;"></span> <b>Verde mela</b> apple green, verde manzana</li> <li><span style="display: inline-block; width: 15px; height: 15px; background-color: #E0E0E0; border: 1px solid black; margin-right: 5px;"></span> <b>Trasparente satinato</b> satin clear, transparente satinado</li> </ul>
--	--

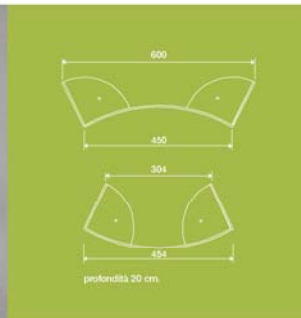

## la tecnomensola

the technoshelf la tecnorepsia

Dal supporto in alluminio partono piani colorati nelle finiture della serie per libere composizioni. Un segno grafico direttamente a parete.

From the aluminium support start off coloured tops in the typical collection finish, ready for free compositions. Graphic design straight on the wall.

Del soporte de aluminio parten tableros coloreados en los acabados de la serie para composiciones libres. Un signo gráfico directamente en la pared.

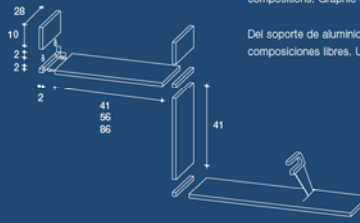

finitura  
**tecnomensola**  
technoshelf finish  
acabados tecnorepsia

<ul style="list-style-type: none"> <li><span style="display: inline-block; width: 15px; height: 15px; background-color: #8B4513; border: 1px solid black; margin-right: 5px;"></span> <b>Cileglio</b> cherrywood, cerezo</li> <li><span style="display: inline-block; width: 15px; height: 15px; background-color: #D2B48C; border: 1px solid black; margin-right: 5px;"></span> <b>Faggio</b> beech, haya</li> <li><span style="display: inline-block; width: 15px; height: 15px; background-color: #8B4513; border: 1px solid black; margin-right: 5px;"></span> <b>Noce</b> walnut, nogal</li> <li><span style="display: inline-block; width: 15px; height: 15px; background-color: white; border: 1px solid black; margin-right: 5px;"></span> <b>Bianco</b> white, blanco</li> <li><span style="display: inline-block; width: 15px; height: 15px; background-color: #D2B48C; border: 1px solid black; margin-right: 5px;"></span> <b>Vaniglia</b> vanilla, vainilla</li> <li><span style="display: inline-block; width: 15px; height: 15px; background-color: #90EE90; border: 1px solid black; margin-right: 5px;"></span> <b>Verde mela</b> apple green, verde manzana</li> <li><span style="display: inline-block; width: 15px; height: 15px; background-color: #90EE90; border: 1px solid black; margin-right: 5px;"></span> <b>Verde acqua</b> aqua green, verde agua</li> <li><span style="display: inline-block; width: 15px; height: 15px; background-color: #4682B4; border: 1px solid black; margin-right: 5px;"></span> <b>Azzurro Shock</b> shocking blue, azul shock</li> <li><span style="display: inline-block; width: 15px; height: 15px; background-color: #4169E1; border: 1px solid black; margin-right: 5px;"></span> <b>Blu</b> blau, azul marino</li> <li><span style="display: inline-block; width: 15px; height: 15px; background-color: #ADD8E6; border: 1px solid black; margin-right: 5px;"></span> <b>Sky</b> blau (sky), celeste (sky)</li> <li><span style="display: inline-block; width: 15px; height: 15px; background-color: #FF8C00; border: 1px solid black; margin-right: 5px;"></span> <b>Fanta</b> orange (fanta), naranja (fanta)</li> <li><span style="display: inline-block; width: 15px; height: 15px; background-color: #FFD700; border: 1px solid black; margin-right: 5px;"></span> <b>Giallo</b> yellow, amarillo</li> <li><span style="display: inline-block; width: 15px; height: 15px; background-color: #DC143C; border: 1px solid black; margin-right: 5px;"></span> <b>Rosso 100%</b> 100% Red, Rojo 100 %</li> </ul>	<ul style="list-style-type: none"> <li><span style="display: inline-block; width: 15px; height: 15px; background-color: #CD5C5C; border: 1px solid black; margin-right: 5px;"></span> <b>Rosso mattone</b> brick red, rojo ladrillo</li> <li><span style="display: inline-block; width: 15px; height: 15px; background-color: #FFD700; border: 1px solid black; margin-right: 5px;"></span> <b>Cedro</b> cedar green, cedro</li> <li><span style="display: inline-block; width: 15px; height: 15px; background-color: #FF8C00; border: 1px solid black; margin-right: 5px;"></span> <b>Mango</b> mango, mango</li> <li><span style="display: inline-block; width: 15px; height: 15px; background-color: #8B4513; border: 1px solid black; margin-right: 5px;"></span> <b>Moka</b> Mocha, Moka</li> <li><span style="display: inline-block; width: 15px; height: 15px; background-color: #A9A9A9; border: 1px solid black; margin-right: 5px;"></span> <b>Tortora</b> turtle dove grey, gris ceniciento</li> <li><span style="display: inline-block; width: 15px; height: 15px; background-color: #A9A9A9; border: 1px solid black; margin-right: 5px;"></span> <b>Visone</b> mink, visón</li> <li><span style="display: inline-block; width: 15px; height: 15px; background-color: #8B4513; border: 1px solid black; margin-right: 5px;"></span> <b>Tabacco</b> tobacco, tabaco</li> <li><span style="display: inline-block; width: 15px; height: 15px; background-color: #9370DB; border: 1px solid black; margin-right: 5px;"></span> <b>Milka</b> milka, milka</li> <li><span style="display: inline-block; width: 15px; height: 15px; background-color: #90EE90; border: 1px solid black; margin-right: 5px;"></span> <b>Verde Pistacchio</b> pistachio green, verde pistachio</li> <li><span style="display: inline-block; width: 15px; height: 15px; background-color: #90EE90; border: 1px solid black; margin-right: 5px;"></span> <b>Verde Prato</b> meadow green, verde prado</li> <li><span style="display: inline-block; width: 15px; height: 15px; background-color: #8B4513; border: 1px solid black; margin-right: 5px;"></span> <b>Bordeaux</b> bordeaux, burdeos</li> <li><span style="display: inline-block; width: 15px; height: 15px; background-color: #A9A9A9; border: 1px solid black; margin-right: 5px;"></span> <b>Alluminio</b> aluminium, aluminio</li> </ul>
--	---



# LIBRERIA SPALLA

SHOULDER BOOKCASE LIBRERIA ESTRIBO

Una composizione ideata utilizzando l'infinita possibilità di combinazione dei moduli fly-team. Elementi liberi e accostamenti articolati, con una costante precisa: arredare con la fantasia.

A composition designed using the endless combination possibilities of the fly-team modules. Free element and articulated combinations, with a precise constant: imaginative furnishing.

Una composición creada utilizando las infinitas posibilidades de combinación de los módulos fly-team. Elementos libres y uniones articuladas, con una constante precisa: amueblar con imaginación.





composizione **712**

Armadio H. 227,2 cm.

**finiture** finishes, acabados.

**finiture struttura**  
structure finishes  
acabados estructura

 **Faggio**  
beech, haya

**finiture frontali**  
front finishes  
acabados frontales

 **Giallo**  
yellow, amarillo.

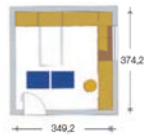



La libreria sfrutta l'angolo inserendosi in armadiature con un cambio di profondità.

The bookcase exploits the corner by fitting in between cabinets with a change in depth.

La libreria aprovecha el ángulo insertándose en composiciones tipo armario con un cambio de profundidad.

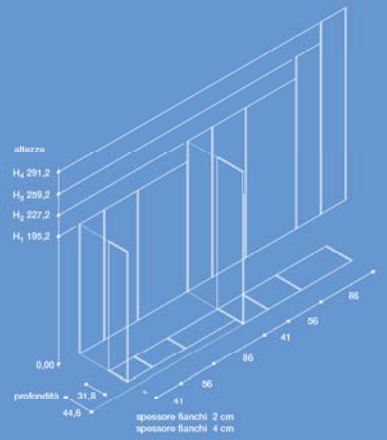



**LA LIBRERIA  
IN SPALLA**

THE SHOULDER BOOKCASE LA LIBRERÍA A ESTRIBO

 **714**  
composizione



composizione **714** Armadio H. 227,2 cm.

finiture finishes, acabados.

finitura struttura  
structure finishes  
acabados estructura

 Noce  
walnut, nogel

finiture frontali  
front finishes  
acabados frontales

 Bianco  
white, blanco

 Blu  
blue, azul

 Sky  
blue, azul





715

composizione

99% design

99% design 99% diseño

La libreria copre le pareti. Piani e spalle dallo spessore di 2 o 4 cm con vani di diverse ampiezze, da affiancare al programma arma

The bookcase covers the walls. Tops and shoulders of thickness 2 or 4 cm with compartments of different sizes, for combining with the cupboard range.

La libreria cubre las paredes. Estantes y respaldos con espesor de 2 o de 4 cm con huecos de diferentes tamaños, para combinarlos con el programa armario.



composizione 715

Armadio H. 227,2 cm.

finiture finishes, acabados.

finitura struttura  
structure finishes  
acabados estructura

Noce  
walnut, nogal

finiture frontali

front finishes

acabados frontales

Sky  
blue (sky), celeste (sky)

Azzurro shock  
strucking blue, azul shock

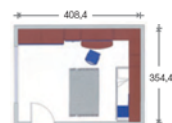



# SCORREVOLI ED **ESTRAIBILI**

SLIDING AND REMOVABLE  
CORREDOZOS Y EXTRAIBLES



 **716**  
composizione

La solida libreria a spalla è capace di diventare armadio, grazie alle ante scorrevoli sui binari che corrono nella linea orizzontale del mobile.  
La scrivania è dotata di un pratico cassetto scorrevole per la riposizione di libri e quaderni.

The solid shoulder bookcase can become a cupboard, thanks to the doors sliding on rails running in the horizontal line of the furniture, while the desk has a handy sliding drawer for holding books.

La sólida librería con respaldo se puede convertir en armario, gracias a las puertas correderas sobre las guías que recorren la línea horizontal del mueble. El escritorio está dotado de un práctico cajón corredizo para guardar libros y cuadernos.



composizione **716**

Armadio H. 259,2 cm.

finiture finishes, acabados:

<p>finiture <b>struttura</b> structure finishes acabados estructura</p>	<p> <b>Faggio</b> beech, haya</p>
<p>finiture <b>frontali</b> front finishes acabados frontales</p>	<p> <b>Blu</b> blue, azul marino</p>

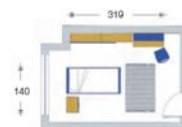

## BOISERIE

BOISERIE BOISERIE

La base del letto diventa una libreria e il piano di appoggio del materasso ospita comodi vani per riporre gli oggetti personali.

The bed base becomes a bookcase and the mattress support table has handy compartments for placing personal objects.

La base de la cama se convierte en librería y el tablero de apoyo del colchón aloja cómodos espacios para guardar los objetos personales.



717

composizioni





composizione **717**

Armadio H. 227,2 cm.

finiture finishes, acabados.

finitura struttura  
structure finishes  
acabados estructura

Bianco  
white, blanco

finiture frontali  
front finishes  
acabados frontales

Finta  
fanta, fanta.  
Blu  
blue, azul marino





718

composizione

Rivestire il muro non solo per stendere calore attorno al letto o raccoglimento nello studio, ma anche per sfruttare la parete come congegno multifunzionale.

La boiserie moderna ha una doppia anima: tecnologica e protettiva.

Covering the wall not only to create warmth around the bed or for comfort in the study, but also to make use of the wall as a multifunctional structure. The modern cladding has a dual soul: technological and protective.

Recubrir la pared no sólo para crear calor alrededor de la cama o una atmósfera acogedora en el estudio, sino también para aprovechar la pared como aparato multifuncional. La boiserie moderna tiene una doble alma: tecnológica y protectora.

TOTALE  
LIBERTÀ

TOTAL FREEDOM LIBERTAD TOTAL

composizione 718

Armadio H. 227,2 cm.

finiture finishes, acabados.

finiture struttura  
structure finishes  
acabados estructura

Bianco  
white, blanco

finiture frontali  
front finishes  
acabados frontales

Verde mela  
apple green, verde manzana

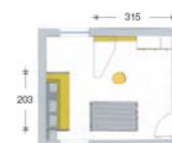



 **719**  
composizione

Alla boiserie fanno riferimento mensole e scrittoi posizionabili lungo i binari, con o senza gambe. Varie sagomature personalizzano il luogo dello studio.

Against the boiserie are shelves and writing tops, positioned on guides, with or without legs. Different shapes for a more personal study area.

A la boiserie hacen referencia repisas y escritorios que se pueden colocar en los rieles, con o sin patas. Diferentes perfiles personalizan la zona estudio.

## LA PARETE SI ORGANIZZA

THE WALL IS ORGANIZED LA PARED SE ORGANIZA



composizione **719**

Armadio H. 259,2 cm.

finiture finishes. acabados.

finiture struttura  
structure finishes  
acabados estructura

 Noce  
walnut, roble

finiture frontali  
front finishes  
acabados frontales

 Verde mela  
apple green, verde manzana

 Verde acqua  
aqua green, verde agua

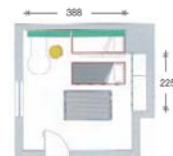



720  
composizione

## LA BOISERIE LETTI SCORREVOLI

THE BOISERIE. SLIDING BEDS.  
LA BOISERIE. CAMAS CORREDIZAS

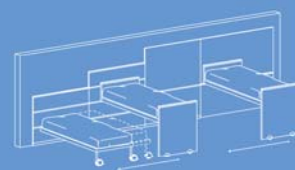

composizione 720

Armadio H. 195,2 cm.

finiture finishes, acabados.

finiture struttura  
structure finishes  
acabados estructura

Cilegio  
cherrywood, cerezo

finiture frontali  
front finishes  
acabados frontales

Cilegio  
cherrywood, cerezo  
Azzurro Shock  
shocking blue, azul shock  
Giallo  
yellow, amarillo

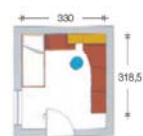



La testata rivestita in tessuto si aggancia alla boiserie. Scegliete voi il colore...

The fabric covered headboard can be attached to the boiserie. You choose the colour...

El cabezal recubierto en tejido se engancha a la boiserie. Ustedes eligen el color...



721  
composizione



composizione 721

Armadio H. 227,2 cm.

finiture finishes, acabados.

frutture struttura  
structure finishes  
acabados estructura

Bianco  
white, blanco

frutture frontali  
front finishes  
acabados frontales

Giallo  
yellow, amarillo

Fanta  
orange (fanta), naranja (fanta)

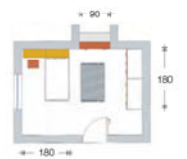



722  
composizione







**PIANI SCRITTOI  
CON RUOTE**  
DESK TOPS ON WHEELS  
TABLEROS ESCRITORIO CON RUEDAS

**il muro non è mai stato così utile**  
Never was a wall so handy  
Nunca una pared resultó tan útil

La boiserie consente una totale libertà nello gestire la disposizione degli elementi. Ne beneficia lo scrittoio, che montato su ruote si posiziona sempre al meglio.

The boiserie allows total freedom in arranging elements. The writing desk, mounted on wheels, gets the most of it, always positioned to the best.

La boiserie otorga libertad total para disponer los elementos. De ello trae ventajas el escritorio, que montado sobre ruedas encuentra siempre la mejor posición.

composizione **722**

Armadio H. 227,2 cm.

finiture finishes. acabados.

finiture **struttura**  **Bianco**  
struttura finishes  white, blanco  
acabados estructura

finiture **frontali**  **Bianco**  
front finishes  white, blanco  
acabados frontales  **Blu**  
 blue, azul marino  
 **Giallo**  
 yellow, amarillo

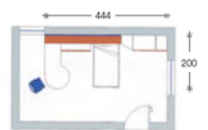



## SI FA PRESTO A DIRE LETTO

JUST THE TIME IT TAKES TO SAY "BED"  
CAMA SE DICE PRONTO

Si fa presto a dire letto. E si fa presto anche a spostarlo. La boiserie realizza l'incontro sinergico di una struttura a ponte e di un letto a castello. Ma non tradizionale. Perché le ruote del fianco a pannello lo fanno scorrere lungo la parete, dando alla camera un assetto variabile al variare delle attività.

Just the time it takes to say "bed", and it is soon moved. The boiserie leads to a synergic meeting of bridge and bunk bed. But not a traditional one. Because the wheels on the side panel make it slide along the wall, changing the bedroom arrangement in line with changing needs.

Cama se dice pronto. Y también se mueve rápido. La boiserie realiza el encuentro sinérgico de una estructura a puente y de una litera. Mas no tradicional. Porque las ruedas del lado a panel la hacen moverse a lo largo de la pared, dan a la habitación un aspecto que varía en cuanto cambian las actividades.



# CASTELLI

BUNK BEDS LITERAS

Il letto si raggiunge attraverso le originali "scale cassettiere" e diventa uno spazio tutto speciale che ospita la scrivania attrezzata.

The bed is reached by means of the original "drawer chest stairs" and becomes a special space that holds the equipped writing-desk.

A la cama se llega a través de las originales "escaleras cajoneras" y se convierte en un espacio muy especial en que se aloja el escritorio equipado.

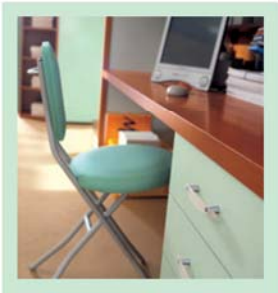

composizione **723** Armadio H. 227,2 cm.

finiture finishes. acabados.

finiture **struttura**  **Ciliagio**  
struttura finishes **cherrywood, cerizzo**  
acabados estructura

finiture **frontali**  **Verde acqua**  
front finishes **agua green, verde agua**  
acabados frontales

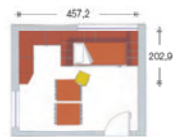



724

composizione

LA TUA ISOLA  
YOUR ISLAND TU ISLA

Dormo, scendo e studio.  
E nella cabina armadio trovo  
cosa mettermi prima d'uscire.

I will sleep, then go down and study.  
And in the cabin wardrobe I will find what  
to put on before I go out.

Duermo, bajo y estudio. Y en la cabina  
armario encuentro lo que pongo antes  
de salir.



POSSIBILITÀ DI SALITA PER IL LETTO A CASTELLO "RIQUADRO"  
Ways up for the "Riquadro" bunk beds  
Posibilidad de subir por la litera "Riquadro"

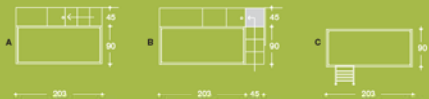

POSSIBILITÀ DI SALITA PER IL LETTO A CASTELLO "MASSELLO"  
Ways up for the "Massetto" bunk beds  
Posibilidad de subir por la litera "Massetto"



A/D:  
PEDANA CON BOTOLA + SCALETTA TRE GRADINI  
Platform with hatch + short three steps stairs  
Tarima con trampilla + escalera tres escalones

B/E:  
PEDANA + PEDANA CON BOTOLA + QUARTO GRADINO  
+ SCALETTA TRE GRADINI  
Platform + platform with hatch + fourth step + short three steps  
stairs.  
Tarima + tarima con trampilla + cuarto escalón + escalera tres  
escalones

F:  
QUARTO GRADINO + SCALETTA TRE GRADINI  
(PER SALITA LATERALE)  
Fourth step+short three steps stairs (to go up on the side)  
Cuarto escalón+escalera tres escalones (para subida lateral)

G/G:  
ALLE SOLUZIONI DI SALITA DEI LETTI A CASTELLO SI PUÒ  
AGGIUNGERE QUELLA CON SCALETTA IN METALLO  
Both bunk beds can also have an added metal ladder  
A las soluciones de subida de los dos literas se puede añadir la  
solución con escalera metálica.



composizione 724

Armadio H. 227,2 cm.

finiture finishes. acabados.

finiture struttura structure finishes acabados estructura	Ciliegio cherrywood, cerezo
finiture frontali front finishes acabados frontales	Azzurro Shock shocking blue, azul shock

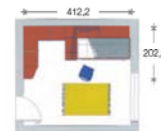



725

composizione

La combinazione tra **bolserie** e letto a castello consente di **attrezzare la zona per la lettura con mensola, pensili e scrittoio sospeso**. Il comodino **vaga liberamente su ruote dal letto allo studio**.

Thanks to a combination of **wainscots** and bunk beds it is possible to **equip the study corner with shelves, wall units and a projecting desk**. The bedside table **moves freely on castors, from the bed to the study area**.

La combinación entre **bolserie** y litera permite equipar la zona para la **lectura con repisa, módulos colgantes y escritorio suspendido**. La mesa de noche **vaga libremente sobre ruedas desde la cama al estudio**.

**C'È POSTO PER DUE**  
THERE'S ROOM FOR TWO HAY SITIO PARA DOS

composizione **725**

Armadio H. 227,2 cm.

finiture finishes. acabados.

**finiture struttura**  
structure finishes  
acabados estructura

**Noce**  
walnut, nogal

**finiture frontali**  
front finishes  
acabados frontales

**Blu**  
blau, azul marino  
**Azzurro Shock**  
shocking blau, azul shock





726

composizione





## Ecco la soluzione

Here is the solution Aquí está la solución

La cameretta come spazio notte o zona studio, ecco la soluzione. Il letto assume funzioni diverse: libreria e scrivania, spazio notte e scala-cassettiera; per chi sceglie l'indipendenza, l'originale letto su ruote.

The children's bedroom as a sleeping and study zone, and here is the solution. The bed has different functions: a bookcase and writing desk, sleeping space and "drawer-chest stairs"; for those choosing independence, there is the bed on wheels.

La pequeña habitación como espacio noche o zona estudio, ésta es la solución. La cama asume funciones diferentes: librería y escritorio, espacio noche y estera-cajonera; para quien elige la independencia, la original cama sobre ruedas.



composizione 726

Armadio H. 227,2 cm.

finiture finishes, acabados.

finiture struttura  
structure finishes  
acabados estructura

Faggio  
beech, haya

finiture frontali  
front finishes  
acabados frontales

Azzurro Shock  
shocking blue, azul shock

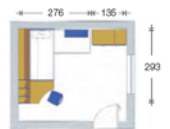





727  
composizioni

## PONTI E SOPPALCHI

BRIDGES AND GALLE PUEBOS Y ALTILLOS

Uno spazio ben organizzato, agile e insieme compatto; l'armadio a ponte contiene il letto estraibile su ruote.

A well-organized, versatile and compact space; the bridge cupboard holds the pullout bed on wheels.

Un espacio bien organizado, ágil y al mismo tiempo compacto; el armario a puente contiene la cama extraíble sobre ruedas.





composizione 727

Armadio H. 259,2 cm.

finiture finishes, acabados.

finiture **struttura**  
structure finishes  
acabados estructura

□ Bianco  
white, blanco

finiture **frontali**  
front finishes  
acabados frontales

□ Bianco  
white, blanco  
■ Verde acqua  
aqua green, verde agua

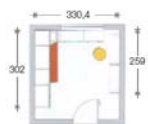

composizione 728

Armadio H. 259,2 cm.

finiture finishes, acabados.

finiture **struttura**  
structure finishes  
acabados estructura

□ Bianco  
white, blanco

finiture **frontali**  
front finishes  
acabados frontales

□ Bianco  
white, blanco  
■ Verde acqua  
aqua green, verde agua





729

composizione





Una zona studio compatta e spaziosa, accanto ad una zona notte piena di fantasia: un letto nell'altro e opla... la scrivania estraibile compare da sotto il letto.

A compact and spacious study zone, next to a sleeping zone full of imagination: a bed in the other and, alley-oop... the pullout desk appears from under the bed.

Una zona estudio compacta y espaciosa, a lado de una zona noche con mucha imaginación: una cama dentro de otra y...de pronto el escritorio extraible aparece de debajo de la cama.



composizione 729

Armadio H. 259,2 cm.

finiture finishes. acabados.

finiture struttura  
structure finishes  
acabados estructura

Faggio  
beech, haya

finiture frontali  
front finishes  
acabados frontales

Verde mela  
apple green, verde marziana

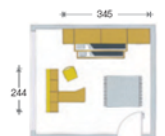



# 730

composizione

Il vivace sopralco  
trasforma la camera  
a due piani; la zona  
letto diventa uno  
spazio tutto personale.  
Ma c'è posto anche  
per lo studio, con  
l'originale scrivania  
dalle forme  
arrotondate.

The lively gamet converts into a  
two-floor bedroom; the sleeping  
area becomes an entirely  
personal space. But there's also  
room for study, with the original  
writing-desk with rounded  
shapes.

El alegre attilo transforma la  
habitación en duplex; la zona  
cama se convierte en un espacio  
muy personal.  
Pero hay sitio también para el  
estudio, con el original escritorio  
de formas redondeadas.



composizione **730** Armadio H. 259,2 cm.

finiture finishes, acabados.

finiture struttura  
structure finishes  
acabados estructura

Faggio  
beech, haya

finiture frontali  
front finishes  
acabados frontales

Bianco  
yellow, amarillo,  
Giallo  
yellow, amarillo,

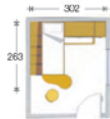



731

composizione

Diamo luce al fianco.  
Molto concrete le  
scale che conducono  
nel mondo dei sogni:  
sono quattro bei  
cassettoni.

Let's give light to the side.  
Very solid the stairs that lead  
to the land of dreams: four  
nice chests.

Hay que darle luz al lateral.  
Muy concretas las escaleras  
que llevan al mundo de los  
sueños: son cuatro bonitos y  
grandes cajones.



composizione **731**

Armadio H. 259,2 cm.

finiture finishes acabados

finiture **struttura**  
structure finishes  
acabados estructura

**Bianco**  
white, blanco

finiture **frontali**  
front finishes  
acabados frontales

**Bianco**  
white, blanco

**Azzurro Shock**  
shocking blue, azul shock

**Verde mela**  
apple green, verde manzana





732  
composizione







composizione 732

Armadio H. 259,2 cm.

finiture finishes, acabados.

<p>finiture <b>struttura</b> structura finishes acabados estructura</p>	<p> <b>Cillegio</b> cherrywood, cerezo</p>
<p>finiture <b>frontali</b> front finishes acabados frontales</p>	<p> <b>Sky</b> blue (sky), celesta (sky)</p>

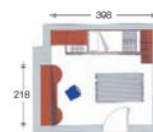



**733**  
 composizione



composizione **733**

Armadio H. 259,2 cm.

**finiture** finishes. acabados.

**finiture struttura**  
 structure finishes  
 acabados estructura

**Ciliegio**  
 cherrywood, cerezo

**finiture frontali**  
 front finishes  
 acabados frontales

**Ciliegio**  
 cherrywood, cerezo  
**Fanta**  
 orange (fanta), naranja (fanta)

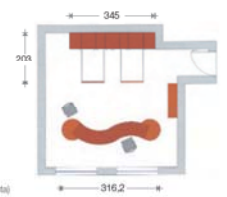





**734**  
 composizione

composizione **734** Armadio H. 259,2 cm.

finiture finishes. acabados.

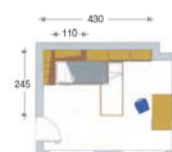
finiture <b>struttura</b> structure finishes acabados estructura	 <b>Faggio</b> beech, haya
finiture <b>frontali</b> front finishes acabados frontales	 <b>Bianco</b> white, blanco  <b>Blu</b> blue, azul marino



 **735**  
composizione

L'arredo si struttura come una vera e propria architettura per l'interno, progettando ponti, accessi a piani rialzati e quant'altro può dare alla camera uno sviluppo globale sfruttando tutte le dimensioni e i colori delle finiture.

The furniture is structured as real interior architecture, designing bridges, access to raised floors and anything that can give the room an overall development exploiting all the dimensions and colours of the finishes.

El amueblado se estructura como una auténtica arquitectura para interiores, proyectando puentes, vías de acceso a los altitos y todo lo que pueda brindar a la habitación un desarrollo global aprovechando todas las dimensiones y los colores de los acabados.



## UNO, DUE, **TRE LETTI**

ONE, TWO, THREE BEDS | UNA CAMA, DOS CAMAS, TRES CAMAS



**Tra ponte e sopralco scorre dinamismo, e funzionalità. Solo così tre letti stanno dove ci sarebbe spazio solo per uno.**

Between bridge and gallery run dynamism and functionality. That's how you have three beds where there is only room for one.

Entre el puente y el altillo hay dinamismo, y funcionalidad. Sólo de esta manera caben tres camas donde habría espacio únicamente para una.



composizione **735**

Armadio H. 259,2 cm.

**finiture** finishes, acabados.

finiture **struttura**  **Faggio**  
 struttura **fratasa** beech, haya  
 acabados **estructura**

finiture **frontali**  **Bianco**  
 front **fratasa** white, blanco  
 acabados **frontales**

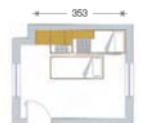



**736**  
 composizione

## SOPPALCO GUARDAROBA

WARDROBE GARRET ALTILLO GUARDARROPA

composizione **736** Armadio H. 227,2 cm.

finiture finishes, acabados.

**finiture struttura**  
 structure finishes  
 acabados estructura

 Faggio  
 beech, haya

**finiture frontali**  
 front finishes  
 acabados frontales

 Faggio  
 beech, haya  
 Vaniglia  
 vanilla, vainilla



**SALIRE AL CASTELLO**  
CLIMB UP TO THE CASTLE SUBIR A LA LITERA



**737**  
composizione





Un castello ha mille architetture. può avere una scala a pioli e una paretina protettiva nello stesso tubolare in finitura alluminio.

A bunk bed can have a thousand different architectures. It can also have a ladder and a small protecting wall made of the same tubular structure, in aluminium finish.

Una litera tiene infinidad de soluciones arquitectónicas: puede tener una escalera de mano y una pequeña pared de protección en el mismo tubular con acabados en aluminio.



composizione 737 Armadio H. 227,2 cm.

finiture finishes, acabados.

finiture struttura  
structure finishes  
acabados estructura

Ciliegio  
cherrywood, cerezo

finiture frontali  
front finishes  
acabados frontales

Ciliegio  
cherrywood, cerezo  
Azzurro Shock  
shocking blue, azul shock

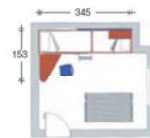



 **738**  
composizione



**ANGOLO  
RISOLTO**  
WARDROBE GARRET ALTILLO GUARDARROPA



composizione **738** Armadio H. 259,2 cm.

finiture finishes, acabados.

finiture struttura  
structure finishes  
acabados estructura

 Faggio  
beech, haya

finiture frontali  
front finishes  
acabados frontales

 Azzurro Shock  
shocking blue, azul shock





Panfil e sopralci



739

composizione

Poco spazio ma ben studiato, e c'è posto per tutto. Il letto si rivela pieno di risorse nascoste; un letto scorre da sotto per l'amico che ha deciso di fermarsi e al mattino, un tocco e tutto torna come prima.

Limited but well-design space, and there's room for everything. The bed proves to be full of hidden resources; a bed slides from underneath for the friend who decided to stay overnight, and at a touch everything is back in place again.

El espacio es poco, pero bien estudiado, y hay sitio para todo. La cama tiene recursos insospechados; una cama se desliza desde abajo para el amigo que ha decidido quedarse a dormir y por la mañana, un toquecito y todo vuelve a estar como antes.



composizione 739 Armadio H. 259,2 cm.

finiture finishes acabados

finiture struttura  
structure finishes  
acabados estructura

Bianco  
white, blanco

finiture frontali  
front finishes  
acabados frontales

Azzurro Shock  
shocking blue, azul shock  
Verde mela  
apple green, verde manzana

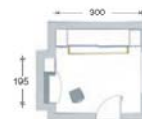

# LA FANTASIA È PROGETTO

IMAGINATION IS DESIGN IMAGINACIÓN ES PROYECTO



Modulo contenitore a sinistra, fianco di sostegno a destra, per adeguare il ponte a tutte le pareti. Sotto, a vostra scelta, il letto o lo studio, organizzato con lo scrittoio girevole montato su cassetiera fissa.

A container module to the left, a panel to the right: with these accessories the wardrobe with an open area is perfect for any type of wall. The area below can be used either for the bed or for a study corner, with a turning writing desk rotating on a fixed chest of drawers.

Módulo contenedor a la izquierda, montante a la derecha, para adecuar el puente a todas las paredes. Debajo, a placer, la cama o el estudio, organizado con el escritorio giratorio montado sobre una cajonera fija.



## SALVASPAZIO

THE ROOM SAVERS LOS SALVAESPACIO

Solida, spaziosa e ben organizzata, la cameretta sa trovare anche negli angoli tanti segreti con l'anta salvaspazio utile in tutte le situazioni più difficili da risolvere.

Solid, spacious and well-organized, the children's bedroom holds many secrets even in the corners with the space-saving door that is handy in all hard to solve situations.

Sólida, espaciosa y bien organizada, la pequeña habitación guarda hasta en los rincones muchos secretos con la puerta salva-espacio útil en cualquier situación, solucionando todos los problemas.



740

composizioni





## I SEGRETI DEGLI ANGOLI

THE SECRETS OF THE CORNERS LOS SECRETOS DE LOS RINCONES

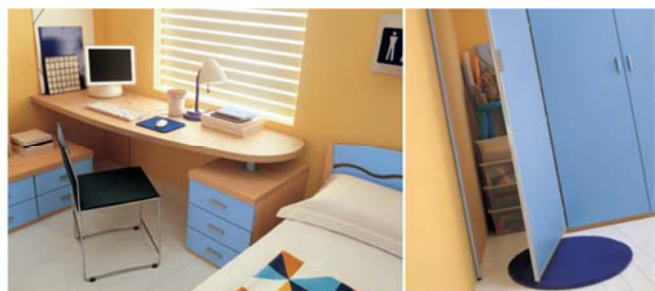

composizione **740** Armadio H. 227,2 cm.

finiture finishes, acabados.

finiture struttura  
structure finishes  
acabados estructura

Faggio  
beech, haya

finiture frontali  
front finishes  
acabados frontales

Azzurro Shock  
stocking blue, azul shock





## ANTA SALVASPAZIO

THE ROOM SAVING DOOR  
LA PUERTA SALVAESPACIO



Angolo di apertura dell'anta  
 $\alpha$  min 90° -  $\alpha$  max 160°



L'anta salvaspazio con sistema MAB è pensata appositamente per chiudere nicchie o per diventare facile elemento di aggiustaggio. L'angolo di apertura dell'anta è variabile da 90° a 160°.

The room saving door (MAB system) is especially designed to close up niches or become an easy adjusting element. The door aperture angle can vary between 90° and 160°.

La puerta salvaspacio con sistema MAB está pensada expresamente para cerrar nichos o para convertirse en un sencillo elemento de ajuste. El ángulo de abertura de la puerta es variable entre los 90° a los 160°.





**741**  
 composizione

**LE CABINE**  
 THE CABINS LAS CABINAS

composizione **741**

Armadio H. 227,2 cm.

finiture finishes. acabados:

<p><b>finiture struttura</b>          struttura finishes          acabados estructura</p>	<p> <b>Faggio</b>          beech, haya</p>
<p><b>finiture frontali</b>          front finishes          acabados frontales</p>	<p> <b>Blu</b>          blue, azul marino</p> <p> <b>Verde mela</b>          apple green, verde manzana</p>

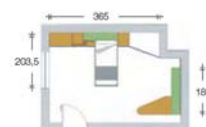

# CABINA ATTREZZATA

EQUIPPED BOOTH  
CABINA EQUIPADA

Apri le ante con profilo alluminio e scoprirai un'ampia cabina ripostiglio, attrezzata con cassettera su ruote e mensole a telaio metallico.

Open the doors with aluminium lining and you'll discover a large cabin closet, equipped with drawer unit on wheels and metal frame shelves.

Abre las puertas con perfil de aluminio y descubrirás una amplia cabina trastero, equipada con cajonera sobre ruedas y repisas con estructura metálica.

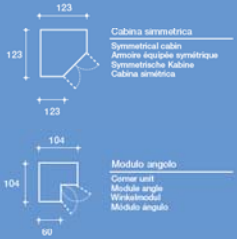

Cabina simmetrica  
Symmetrical cabin  
Armoire équilibre symétrique  
Symmetrische Kabine  
Cabina simétrica

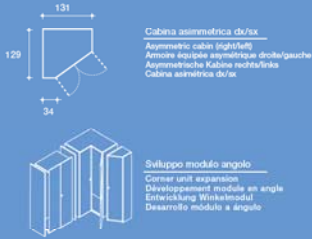

Cabina asimmetrica dx/sx  
Asymetric cabin (right/left)  
Armoire équilibre asymétrique droite/gauche  
Asymmetrische Kabine rechts/links  
Cabina asimétrica dx/sx

Sviluppo modulo angolo  
Corner unit expansion  
Développement module an angle  
Entwicklung Winkelmodul  
Desarrollo módulo a ángulo





747

composizione

## ANTE SCORREVOLI

SLIDING DOORS  
PUERTAS CORREDERAS

composizione 747

Armadio H. 227,2 cm.

finiture finishes, acabados.

finiture struttura

structure finishes

acabados estructura

Noce  
walnut, roble

Giallo  
yellow, amarillo

Verde mela  
apple green, verde manzana

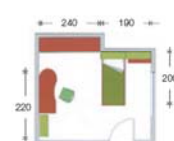



Il letto "Wagon Lit" sa stare veramente dappertutto, fino a mimetizzarsi elegantemente con la libreria del soggiorno.

The "Wagon Lit" bed fits in anywhere, even elegantly matching the bookcase of the living-room.

La cama "Wagon Lit" sabe estar realmente en todas partes, hasta mimetizarse elegantemente con la librería de la sala de estar.



composizione **742**

Armadio H. 227,2 cm.

finiture finishes, acabados.

finiture **struttura**  **Noce**  
structure finishes walnut, nogel  
acabados estructura

finiture **frontali**  **Bianco**  
front finishes white, blanco  
acabados frontales

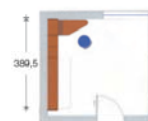

## WAGON LIT

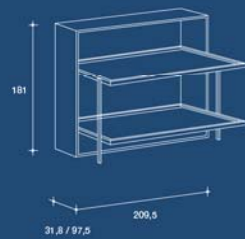

Wagon Lit è corredato di scaletta, che diviene protezione anticaduta. Il letto a castello. Oppure un letto singolo. Il modulo per un letto.

Wagon Lit comes with a short ladder, that turns into a protection rail. The bunk bed. Or else a single bed. A bed unit. A bed unit.

Wagon Lit está dotado de escalerita, que se convierte en protección anticaída. La litera. O bien una cama individual. El módulo para una cama.



# ARMADI

CUPBOARDS EVERYWHERE ARMARIOS POR DOQUIERA

La parete stessa diventa guardaroba e l'armadio può mimetizzarsi con ogni tipo di spazio.

The wall becomes a wardrobe and the cupboards blend in with any type of space.

La propia pared se convierte en guardaropa y el armario puede mimetizarse con cualquier tipo de espacio.



## finiture ante liscie

lacquered finish  
acabados tecnospies

 <b>Cilegio</b> cherrywood, cersazo	 <b>Rosso mattone</b> brick red, rojo ladrillo
 <b>Faggio</b> beech, haya	 <b>Cedro</b> cedar green, cedro
 <b>Noce</b> walnut, nogal	 <b>Mango</b> mango, mango
 <b>Bianco</b> white, blanco	 <b>Moka</b> Mocha, Moka
 <b>Vaniglia</b> vanilla, vanille	 <b>Tortora</b> turtle-dove gray, gris cisordito
 <b>Verde mela</b> apple green, verde manzana	 <b>Visone</b> mink, visón
 <b>Verde acqua</b> aque green, verde agua	 <b>Tabacco</b> tobacco, tabaco
 <b>Azzurro Shock</b> shocking blue, azul shock	 <b>Milk</b> milk, milka
 <b>Blu</b> blue, azul marino	 <b>Verde Pistacchio</b> pistachio green, verde pistacho
 <b>Sky</b> blue (sky), celeste (sky)	 <b>Verde Prato</b> meadow green, verde prado
 <b>Fanta</b> orange (fanta), naranja (fanta)	 <b>Bordeaux</b> bordeaux, burdeos
 <b>Giallo</b> yellow, amarillo	 <b>Alluminio</b> aluminium, aluminio
 <b>Rosso 100%</b> 100% red, rojo 100 %	



## DISEGNA CON IL COLORE

THE ROOM SAVING LOS SALVAESPACIO

La geometria bicolor dell'anta inglesina permette di alternare liberamente i quadrati colorati, creando composizioni personali.

The two-tone geometrical shape of the English-style door allows the coloured squares to be freely alternated, creating personal compositions.

La geometría bicolor de la puerta inglesa permite alternar libremente los cuadrados de colores, creando composiciones personales.



# 743

composizione



finiture  
anta inglesina  
inglesina door finish  
acabados puerta  
inglesa

- |  |   |  |  |
|--|---|--|--|
|  | <b>Ciliegio</b><br>cherrywood, cerezo             |  | <b>Rosso mattone</b><br>brick red, rojo ladrillo           |
|  | <b>Faggio</b><br>beech, haya                      |  | <b>Cedro</b><br>cedar green, cedro                         |
|  | <b>Noce</b><br>walnut, nogal                      |  | <b>Mango</b><br>mango, mango                               |
|  | <b>Bianco</b><br>white, blanco                    |  | <b>Moka</b><br>Mocha, Moka                                 |
|  | <b>Vaniglia</b><br>vanilla, vainilla              |  | <b>Tortora</b><br>turquoise grey, gris azulado             |
|  | <b>Verde mela</b><br>apple green, verde manzana   |  | <b>Visone</b><br>mink, visón                               |
|  | <b>Verde acqua</b><br>aqua green, verde agua      |  | <b>Tabacco</b><br>tobacco, tabaco                          |
|  | <b>Azzurro Shock</b><br>shocking blue, azul shock |  | <b>Milka</b><br>milka, milka                               |
|  | <b>Blu</b><br>blue, azul marino                   |  | <b>Verde Pistacchio</b><br>pistachio green, verde pistacho |
|  | <b>Sky</b><br>blue (sky), celeste (sky)           |  | <b>Verde Prato</b><br>meadow green, verde prado            |
|  | <b>Fanta</b><br>orange (fanta), naranja (fanta)   |  | <b>Bordeaux</b><br>bordeaux, burdeos                       |
|  | <b>Giallo</b><br>yellow, amarillo                 |  | <b>Alluminio</b><br>aluminium, aluminio                    |
|  | <b>Rosso 100%</b><br>100% Red, Rojo 100 %         |  |  |

- finiture  
profili  
door finish  
acabados puerta
- |  |   |
|--|---|
|  | <b>Ciliegio</b><br>cherrywood, cerezo   |
|  | <b>Faggio</b><br>beech, haya            |
|  | <b>Noce</b><br>walnut, nogal            |
|  | <b>Bianco</b><br>white, blanco          |
|  | <b>Alluminio</b><br>aluminium, aluminio |



Anta Liscia  
plain door  
puerta lisa



Anta Profilo  
door lining  
puerta perfil



Anta Specchio  
door with mirror  
puerta Espejo



Anta Similvetro  
imitation  
glass door  
puerta imitación  
cristal



Anta Inglesina  
inglesina door  
square panels  
puerta con  
estructura a rejilla  
vetro inglés



Anta Bicolor  
"bicolor" door  
puerta "bicolor"



Anta Serigrafata  
screen printed door  
puerta serigrafada



Anta Fantasia  
fancy door  
puerta fantasia

CLASSICA  
**INGLESINA**

CLASSIC ENGLISH-STYLE DOOR WITH SQUARES  
CLASICA INGLESA



744

composizione





745  
composizione



LE ANTE  
**A PROFILO**  
THE DOORS WITH PROFILE  
LAS PUERTAS MOLDURADAS





L'ANTA **SERIGRAFATA**  
 SCREEN PRINTED DOOR LA PUERTA SERIGRAFIADA

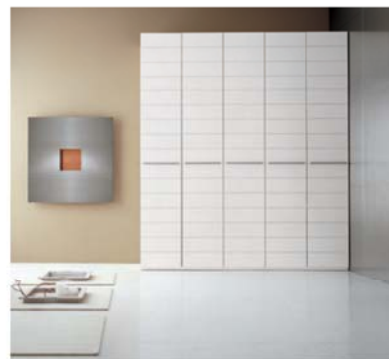

finiture		<input type="checkbox"/>	<b>Bianco</b>
anta serigrafata		<input type="checkbox"/>	white, blanco
inglesina door finish		<input type="checkbox"/>	<b>Vaniglia</b>
acabados puerta		<input type="checkbox"/>	vanilla, vanilla
inglesia		<input type="checkbox"/>	<b>Verde mela</b>
		<input type="checkbox"/>	apple green, verde manzana
		<input type="checkbox"/>	<b>Verde acqua</b>
		<input type="checkbox"/>	aqua green, verde agua
		<input type="checkbox"/>	<b>Azzurro Shock</b>
		<input type="checkbox"/>	shocking blue, azul shock
		<input type="checkbox"/>	<b>Blu</b>
		<input type="checkbox"/>	blue, azul marino
		<input type="checkbox"/>	<b>Sky</b>
		<input type="checkbox"/>	blue (sky), celeste (sky)
		<input type="checkbox"/>	<b>Fanta</b>
		<input type="checkbox"/>	orange (fanta), naranja (fanta)
		<input type="checkbox"/>	<b>Rosso 100%</b>
		<input type="checkbox"/>	100% red, rojo 100 %
		<input type="checkbox"/>	<b>Giallo</b>
		<input type="checkbox"/>	yellow, amarillo
finiture serigrafia		<input type="checkbox"/>	<b>Alluminio</b>
door finish		<input type="checkbox"/>	aluminium, aluminio
acabados puerta		<input type="checkbox"/>	

Le ante a battente sono decorate da elementi orizzontali in alluminio.

The leaf doors are decorated with horizontal elements in aluminium.

Las puertas batientes están decoradas con elementos horizontales en aluminio.





TUTTO **SCORRE**  
EVERYTHING SLIDES    TODO SE DESLIZA

Ante scorrevoli caratterizzare da un inserto centrale, componibili secondo il gusto personale, abbinando le varie tonalità di legno e di laccati.

Sliding doors featuring a central insert: they can be combined according to personal taste, with the various wood and lacquered shades.

Puertas correderas caracterizadas por una inserción central, componibles según el gusto personal, combinando las diferentes tonalidades de madera y de lacreados.

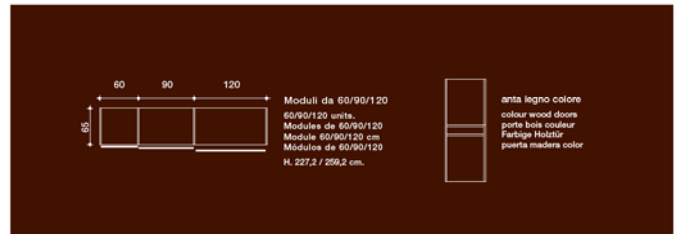

finiture  
anta scorrevole  
finish of sliding doors  
acabados puertas  
correderas

	<b>Ciliegio</b> cherrywood, caesno		<b>Rosso mattone</b> brick red, rojo ladrillo
	<b>Faggio</b> beech, haya		<b>Cedro</b> cedar green, cedro
	<b>Noce</b> walnut, nogal		<b>Mango</b> mango, mango
	<b>Bianco</b> white, blanco		<b>Moka</b> Mocha, Moka
	<b>Vaniglia</b> vanilla, vainilla		<b>Tortora</b> turtle-dove grey, gris cardinalo
	<b>Verde mela</b> apple green, verde manzana		<b>Visone</b> mink, visón
	<b>Verde acqua</b> aqua green, verde agua		<b>Tabacco</b> tobacco, tabaco
	<b>Azzurro Shock</b> shocking blue, azul shock		<b>Milka</b> milka, milka
	<b>Blu</b> blue, azul marino		<b>Verde Pistacchio</b> pistachio green, verde pistacho
	<b>Sky</b> blue (sky), celeste (sky)		<b>Verde Prato</b> meadow green, verde prado
	<b>Fanta</b> orange (fanta), naranja (fanta)		<b>Bordeaux</b> bordeaux, burdeos
	<b>Giallo</b> yellow, amarillo		<b>Alluminio</b> aluminium, aluminio
	<b>Rosso 100%</b> 100% Red, Rojo 100 %		

UN TOCCO  
**DI PERSONALITÀ**

A TOUCH OF PERSONALITY UN TOUQUE PERSONAL



746

composizione



## ECCO L'ARCHIVIO

HERE IS THE ARCHIVE AQUÍ ESTÁ EL ARCHIVO

**I cassetti possono essere attrezzati con elementi porta-cartelle, diventando uno spazio per l'archiviazione dei documenti personali.**

The drawers can be equipped with file-holder elements, becoming a space for holding personal documents.

Los cajones pueden ser equipados con elemento porta-carpetas, para convertirse en un espacio para archivar los documentos personales.



## COMPLEMENTI **flyteam**

COMPLEMENTS COMPLEMENTOS

Puoi trovare la gamma completa nel Catalogo  
**flyteam vol. 02** a pag. **148**

You can find the complete range in the flyteam Catalogue vol. 02 on page 148  
Puedes encontrar la gama completa en el Catálogo flyteam vol. 02 en pag. 148





La ditta MAB INDUSTRIE si riserva la facoltà di modificare in qualunque momento e senza preavviso, le caratteristiche tecniche degli elementi usati nel presente catalogo. Alcuni accessori presenti nelle immagini fotografiche non sono prodotti della ditta MAB INDUSTRIE. Si prega di far riferimento al listino prezzi. La ditta MAB INDUSTRIE si riserva inoltre il diritto di apportare ai propri prodotti quelle modifiche che riterrà necessarie o utili al fine di migliorarli senza pregiudicare le caratteristiche essenziali. È vietata ogni riproduzione totale o parziale in Italia e all'estero.

MAB INDUSTRIE reserves the right to modify the technical characteristics of the elements used in the present catalogue at any time and without warning. Some accessories present in the photographs are not produced by MAB INDUSTRIE. Please refer to price list. MAB INDUSTRIE also reserves the right to carry out modifications which it considers necessary or useful in order to improve its products, without prejudicing the essential characteristics. Total or partial reproduction prohibited in Italy or any other country.

MAB INDUSTRIE se reserva el derecho de modificar en cualquier momento y sin preaviso, las características técnicas de los elementos utilizados en el presente catálogo. Algunos de los accesorios que se encuentran en las imágenes fotográficas no han sido producidos por MAB INDUSTRIE. Se sugiere hacer referencia al listado de precios. MAB INDUSTRIE se reserva además el derecho de modificar sus productos cuando lo considere necesario y útil con el fin de mejorarlos sin perjudicar las características esenciales. Prohíbida la reproducción total o parcial en Italia y en el exterior.

## flyteam un programma per crescere vol. 01

DESIGN: ADRIANI & ROSSI EDIZIONI  
UFFICIO RICERCA E SVILUPPO MAB INDUSTRIE S.P.A.  
EISA OCCHIELI  
DIREZIONE ARTISTICA E GRAFICA: ADRIANI & ROSSI EDIZIONI  
FOTO: STUDIO INDOOR (ODERZO-TV)  
FOTOUTO: EUROGRAFICA (VR)  
STAMPÀ: EUROSTAMPA 2000 (VR) - FEBBRAIO 2007